

SecurePlus Flip Lid

Theft from retailers is on the increase and it is vital that the checkout staff and the daily takings are securely protected at the point of sale. Cash Bases recognise this problem and have developed highly secure units for the storage and safe transportation of cash. Cash Bases security - at the heart of your EPOS.

DESCRIPTION

Based on industry acclaimed forerunners, the SecurePlus Flip Lid has been designed to withstand excessive forced entry.

FEATURES

- Robust steel construction
- Drawer status micro switch
- Heavy duty latching mechanism
- Steel face plate
- Radial pin tumbler lock

OPTIONS

- Wide range of inserts - plastic or steel
- Floppy note dividers to maximize note storage
- Fixed or removable coin cups
- Coin cups suitable for weigh counting
- Anti grab flap over the note compartment
- Media posting slot
- Lockable lid for the insert
- Manual push button release
- No lock
- Base plate for secure fixing & quick release
- Stainless steel finish for the lid

SPECIFICATION

- | | |
|---------------------------------------|-----------------|
| FL-460 | FL-490 |
| ■ Width: 460mm | ■ Width: 490mm |
| ■ Depth: 175mm | ■ Depth: 175mm |
| ■ Height: 100mm | ■ Height: 110mm |
| ■ Weight: dependant on type of insert | |

IDEAL FOR

- Heavy duty scanning environments
- Supermarkets
- Hypermarkets
- Petrol Forecourts

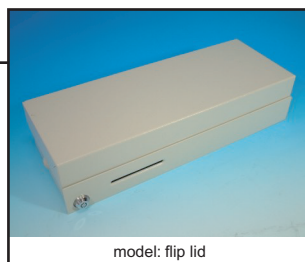
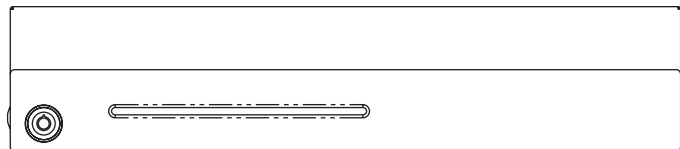
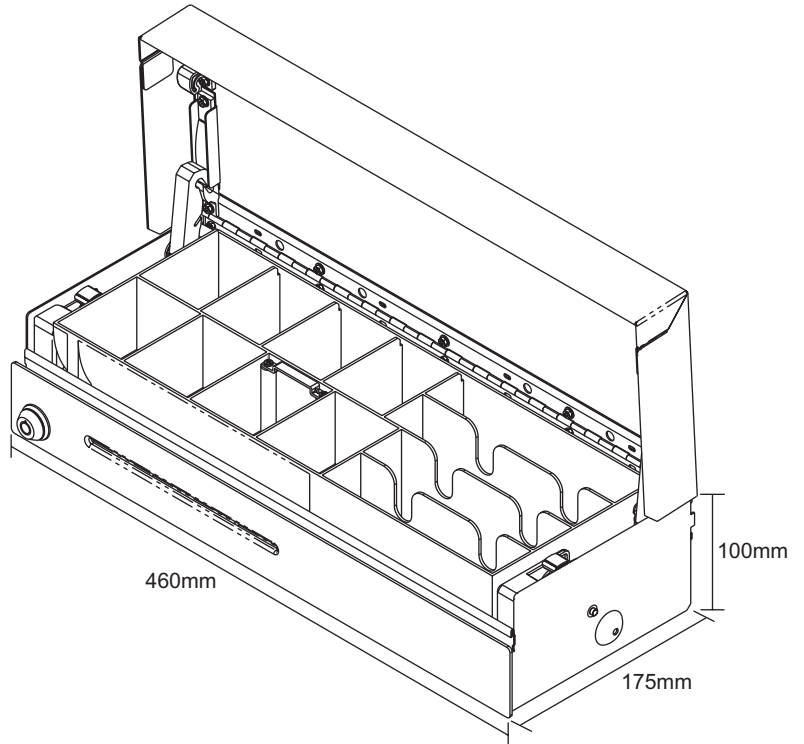

UKSP-FLID-02-1101



Specification may be subject to change without notification

at the heart of your EPOS

CASH BASES LTD ■ NEWHAVEN, EAST SUSSEX BN9 0LA ■ UK ■ www.cashbases.net
 TEL: +44 [0] 1 273 616300 ■ FAX: +44 [0] 1 273 512010 ■ EMAIL: sales@cashbases.co.uk