

## CashPlus Maxi

The CashPlus range has been selected from over 10,000 cash drawer designs developed by Cash Bases during their 20 year history. Each product offers unique features, configurable inserts and variable dimensions, suitable for any retail environment, anywhere in the world. Cash Bases cash drawers - at the heart of your EPOS.

### DESCRIPTION

Very high capacity with flexible insert designs.

### FEATURES

- Robust steel construction
- Steel ball bearing runners
- Drawer status micro switch
- Bolt down facility in baseboard

### OPTIONS

- Wide range of inserts
- Fixed or removable coin cups
- Coin cups suitable for weigh counting
- Up to 4 media posting slots
- Lockable lid for the insert
- Emergency key release, 3 position or no lock
- Alike or random locks
- Support bracket for under counter mounting
- Rear cable guard for cable management

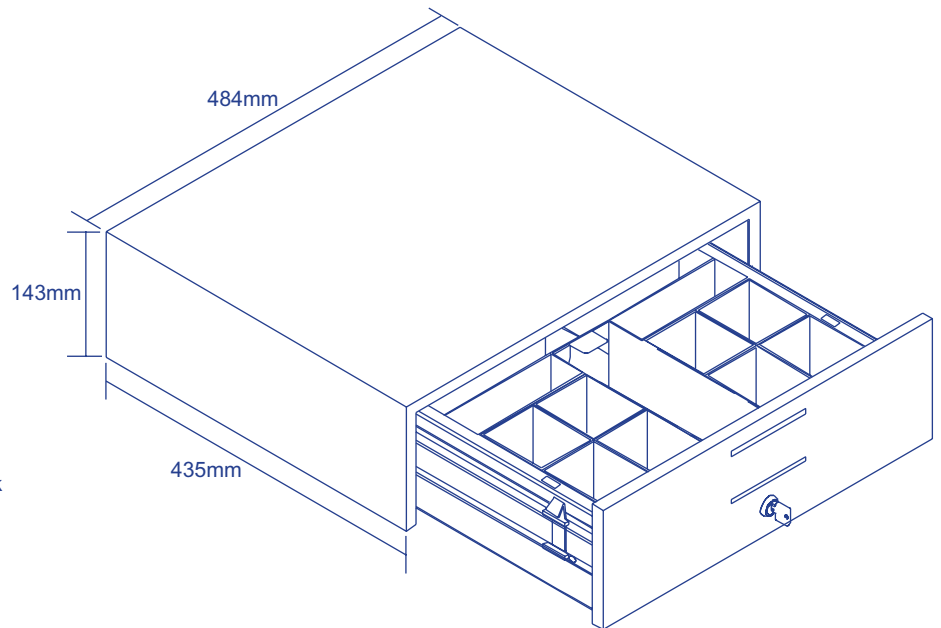

### SPECIFICATION

- Width: 484mm
- Depth: 435mm
- Height: 143mm
- Weight: 16kg

### IDEAL FOR

- Any retail environment
- Department Stores
- Financial Institutions
- PoS System Platform



UK/CASH-MAXI-02-1101



Specification may be subject to change without notification

**at the heart of your EPOS**

CASH BASES LTD ■ NEWHAVEN, EAST SUSSEX BN9 0LA ■ UK ■ [www.cashbases.net](http://www.cashbases.net)  
 TEL: +44 [0] 1 273 616300 ■ FAX: +44 [0] 1 273 512010 ■ EMAIL: [sales@cashbases.co.uk](mailto:sales@cashbases.co.uk)