

CashPlus Flip Lid

The CashPlus range has been selected from over 10,000 cash drawer designs developed by Cash Bases during their 20 year history. Each product offers unique features, configurable inserts and variable dimensions, suitable for any retail environment, anywhere in the world. Cash Bases cash drawers - at the heart of your EPoS.

DESCRIPTION

Industry acclaimed as being the 'Best of Breed' design. The Flip Lid cash drawer is robust, durable and compact, and has become the de facto standard in European supermarket retailing.

FEATURES

- Robust steel construction
- Drawer status micro switch

OPTIONS

- Wide range of inserts - plastic or steel
- Floppy note dividers to maximize note storage
- Fixed or removable coin cups
- Coin cups suitable for weigh counting
- Anti grab flap over note compartment
- Media posting slot
- Lockable lid for the insert
- Integral lockable lid
- Manual push button release
- Emergency key release, 3 position or no lock
- Alike or random locks
- Base plate for secure fixing & quick release
- Stainless steel finish for the lid

SPECIFICATION

FL-460

- Width: 460mm
- Depth: 172mm
- Height: 100mm
- Weight: dependent on type of insert

FL-490

- Width: 490mm
- Depth: 172mm
- Height: 109mm

IDEAL FOR

- Heavy duty scanning environments
- Convenience Stores
- Hypermarkets
- Petrol Forecourts
- Supermarkets

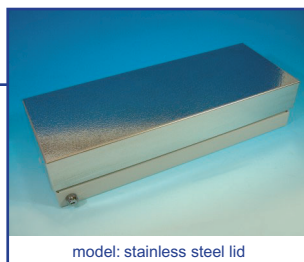
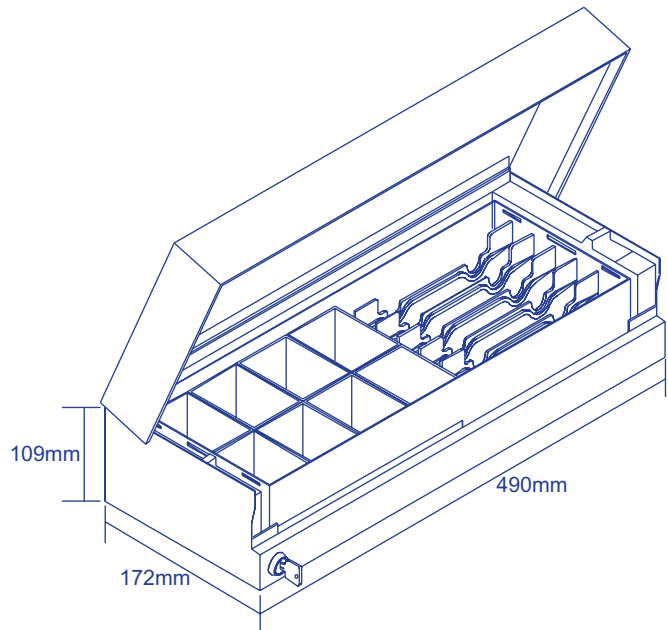
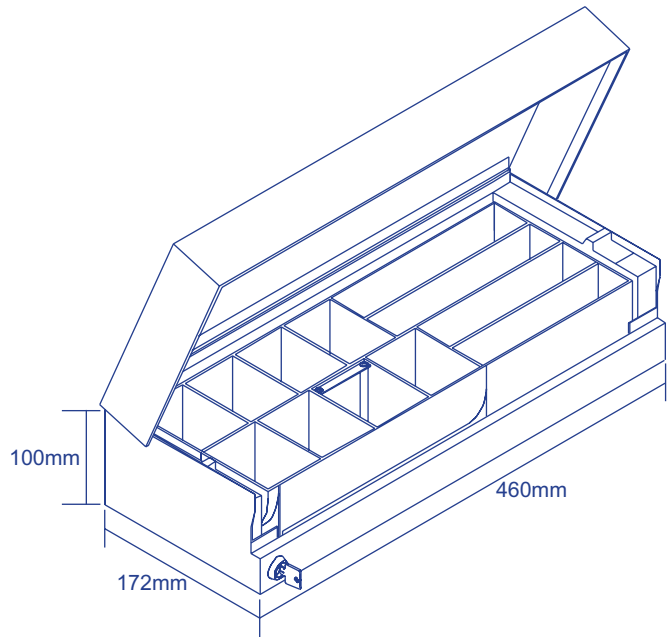

model: stainless steel lid



option: moulded insert



option: universal insert

LUK/CASH/FLIP-02-1101



Specification may be subject to change without notification

at the heart of your EPoS

CASH BASES LTD ■ NEWHAVEN, EAST SUSSEX BN9 0LA ■ UK ■ www.cashbases.net
 TEL: +44 [0] 1 273 616300 ■ FAX: +44 [0] 1 273 512010 ■ EMAIL: sales@cashbases.co.uk