

CashPlus Flexi

The CashPlus range has been selected from over 10,000 cash drawer designs developed by Cash Bases during their 20 year history. Each product offers unique features, configurable inserts and variable dimensions, suitable for any retail environment, anywhere in the world. Cash Bases cash drawers - at the heart of your EPoS.

DESCRIPTION

The compact design of the Flexi cash drawer provides high capacity storage and flexible inserts. The small footprint design compliments the size and aesthetics of today's modular and touch screen EPoS systems.

FEATURES

- Robust steel construction
- Steel ball bearing runners
- Drawer status micro switch
- Bolt down facility in baseboard

OPTIONS

- Wide range of inserts
- Layflat or vertical note storage
- Coin cups suitable for weigh counting
- Media posting slot
- Lockable lid for the insert
- Emergency key release, 3 position, or no lock
- Alike or random locks
- Support bracket for under counter mounting
- Rear cable guard for cable management

SPECIFICATION

- Width: 330mm
- Depth: 427mm
- Height: 118mm
- Weight: 10kg

IDEAL FOR

- Small working environments
- Convenience Stores
- Hospitality

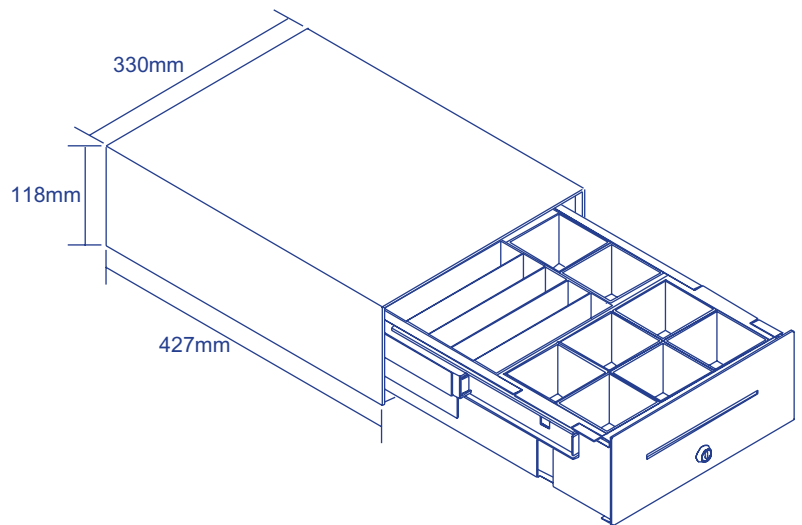
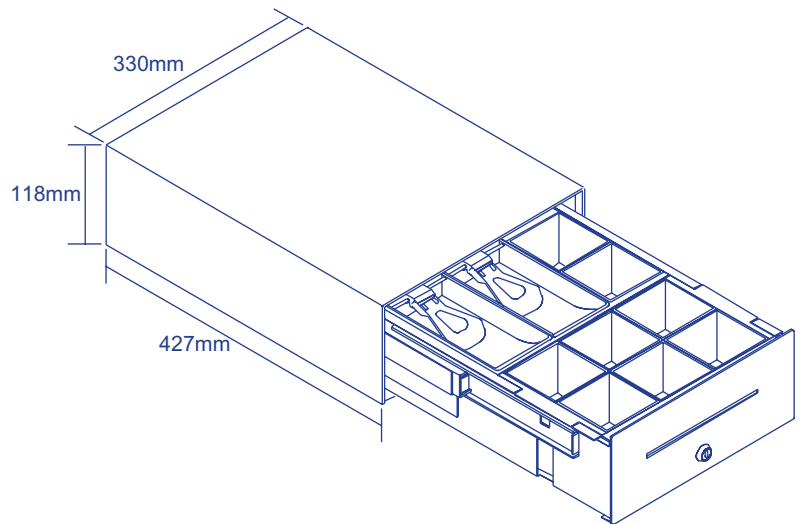

model: flexi



option: vertical note insert



option: layflat note insert

UK/CASH-FLEXI-02-1101



Specification may be subject to change without notification

at the heart of your EPoS

CASH BASES LTD ■ NEWHAVEN, EAST SUSSEX BN9 0LA ■ UK ■ www.cashbases.net
 TEL: +44 [0] 1 273 616300 ■ FAX: +44 [0] 1 273 512010 ■ EMAIL: sales@cashbases.co.uk